

CRANES AND LIFTING EQUIPMENT

Hire a safe crane and lifting equipment at Preston Rentals

We have established ourselves as reliable partner in both the industrial and the building industry. A partner which delivers custom-made solutions fulfilling your needs and demands.

We understand the importance of delivering reliable equipment on time and securing a high level of operation without interruptions.

Our objective is to establish long-term cooperative relations based on trust, dependability and mutual success. We provide impeccable service and create a safe and efficient working environment for you.

With PRESTON RENTALS® as a partner we take you and your industrial and building projects to new heights. We are ready to deliver exceptional expertise and create lasting results which will make a difference.



Choose your equipment

Checklist for choice of equipment

Please consider the following conditions before choosing equipment.

Indoors or outdoors

You should choose electric cranes for indoor jobs.

Electric, battery or diesel

Is there access to electricity?

Placing

Stability is important for safety and comfort.

Obstacles

Check width, height, and radius in your work area.

Work height

At which height will you be working?

What reach do you need?

Lifting capacity

Amount of kg - weight of equipment, materials etc.

Type of work

Light or heavy work?

Do you need outriggers?

If the work has to be done on unstable or inclined surfaces, pressure area calculations should be made.

Permissions

Are permits required to use the crane?

Rental Period

Plan well in advance to ensure you get the right crane for the job.

Delivery of Equipment

How should the crane be transported?

Consider the weight on the trailer/truck.

Additional Equipment

Have you remembered extra cables, steel planks, derricks, tackles, chains, barriers, etc.?

Do ask us about additional equipment!

We are happy to assist you in choosing the right equipment!

When you hire equipment from us, you can be assured that it is in good condition and ready for use.

If you hire for an extended period, we regularly perform on-site inspections and maintenance.

Table of contents

SuperCrane™	4
C1 compact crane	5
C4 compact crane	6
C6 compact crane	7
C10 compact crane	9
C30e compact crane	11
SuperCrane™ SC180	12
SuperCrane™ XM800	14
SuperGlassHandling™	16
320 KG Spider suction	17
320 KG Reach suction	17
135 KG 2 Suction cup	17
600 / 800 / 1000 KG Hoeflon suction	17
VIAVAC	18
SuperGrab™ BX1000	20
MultiTool	22
Crane Accessories	24
SuperElevate™	26
Lumberjack.....	28
MiniMax L3	30
MiniMax L5	31
Lumberjack L20-3.....	32
SuperDeck®	34
SuperPropping™	38
Contact and Services	40

SuperCrane™

Multifunctional, robust and compact cranes



The small power centre C1 compact crane

The Hoeflon C1 Mini Crane lifts up to 600 kg and can access anywhere. It is electrically powered and can therefore be used indoors in enclosed spaces. It is ideal for positioning glass and steel beams.

SPECIFICATIONS

Capacity:	650 kg
Max. hoisting height:	5,6 m og 4,4 m without options
Boom outreach:	4,6 m og 3,3 m without options
Battery:	24 V
Width:	71,2 cm
Controls:	Remote control; proportional driving and lifting
Total weight:	960 kg and 1060 kg with extra equipment
Wire winch:	40 m
Hydraulic slewing range:	136°
Load moment protection:	Overload protection at 90% / 100%

EQUIPMENT

Converter:	230 V / 24 V
Adjustable section:	30° adjustment range
Winch:	460 kg
Tracks:	Non-marking
Storage box:	0,5 m x 0,3 m x 0,3 m
Boom:	30° (up/down)
Work lighting:	LED

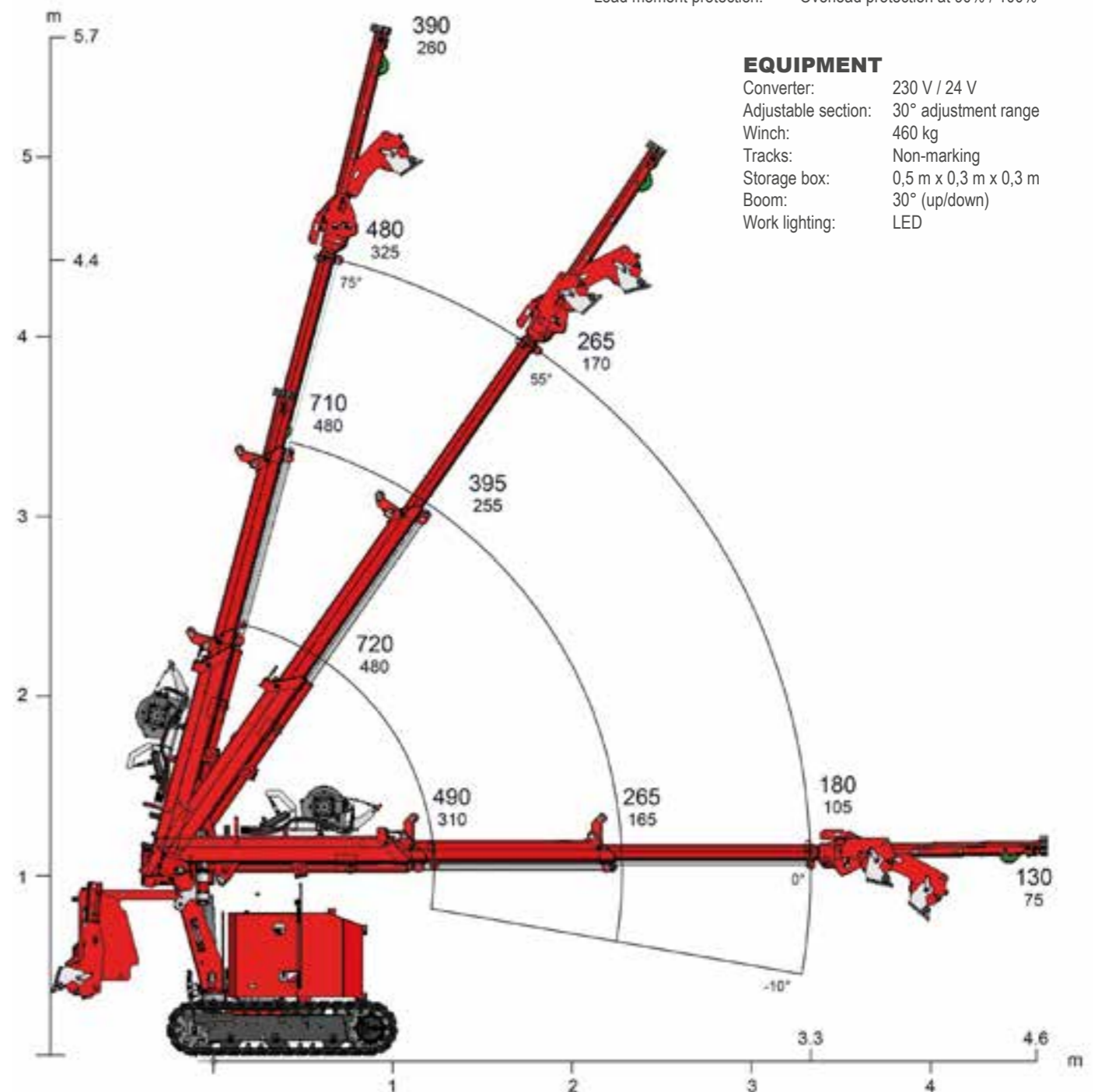

Great prices for crane hire

At PRESTON RENTALS®, you can hire Denmark's best compact crane "to-go". It's possible to pick it up yourself, drive out, perform the work, and return it. We offer crane hire of compact cranes both with and without an operator.

Hire SuperCrane™ with easy control

When we offer compact crane hire, it's important to us that they are easy to operate. They are controlled via a remote control, similar to truck cranes. With the remote control, you can drive the crane's tracks and outriggers. This ensures complete control during manoeuvring and setup.

Once the crane is set up, you can control the crane safely and smoothly with millimetre precision using these remote controls. The remotes also come equipped with an information display that quickly provides an overview of the current lift – load weight, maximum lifting capacity, outreach, etc. Therefore, all our cranes are very easy to use, and crane hire has never been easier.

Are you interested in a quote for your next project?

Our competences are diverse, and we are passionate about helping you. You are always welcome to contact us for further questions. Naturally, we will also provide a non-binding quote for your task.

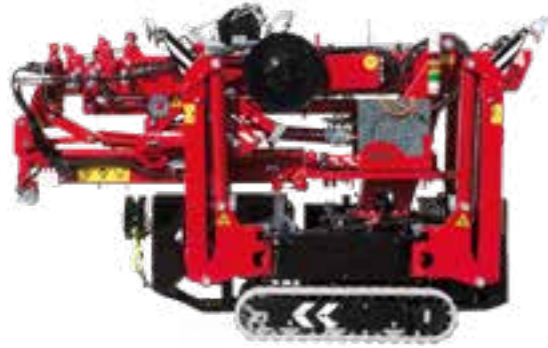

Multifunctional compact crane C4 compact crane

The C4 is an ultra-stable, robust compact crane that lifts up to 2 tons. Its transport flexibility is thanks to its expandable tracks and its low centre of gravity. It is both electric and diesel-powered.

SPECIFICATIONS

Capacity:	2350 kg
Maximum outreach:	11,7 m x 144 kg
Maximum lifting height:	9,7 and 14,6 m including options
Dimensions:	L: 2,8 m x B: 0,75 - 1,1 m x H: 1,82 m
Dimensions incl. winch and jib:	L: 3,04 m x B: 0,75 m x H: 1,95 m
Total weight:	1900 kg – and including options 2150 kg
Ground pressure:	0,59 kg/cm ²

EQUIPMENT

Electric motor:	230 V
Fly jib:	4,3 m
Winch wire:	40 m
Tracks:	Non-marking
Lighting:	Work lamp on boom and fly-jib
Stepless swiveling outriggers:	0 - 90°

Available as both a hybrid (diesel + electric) and as a pure Power battery crane.

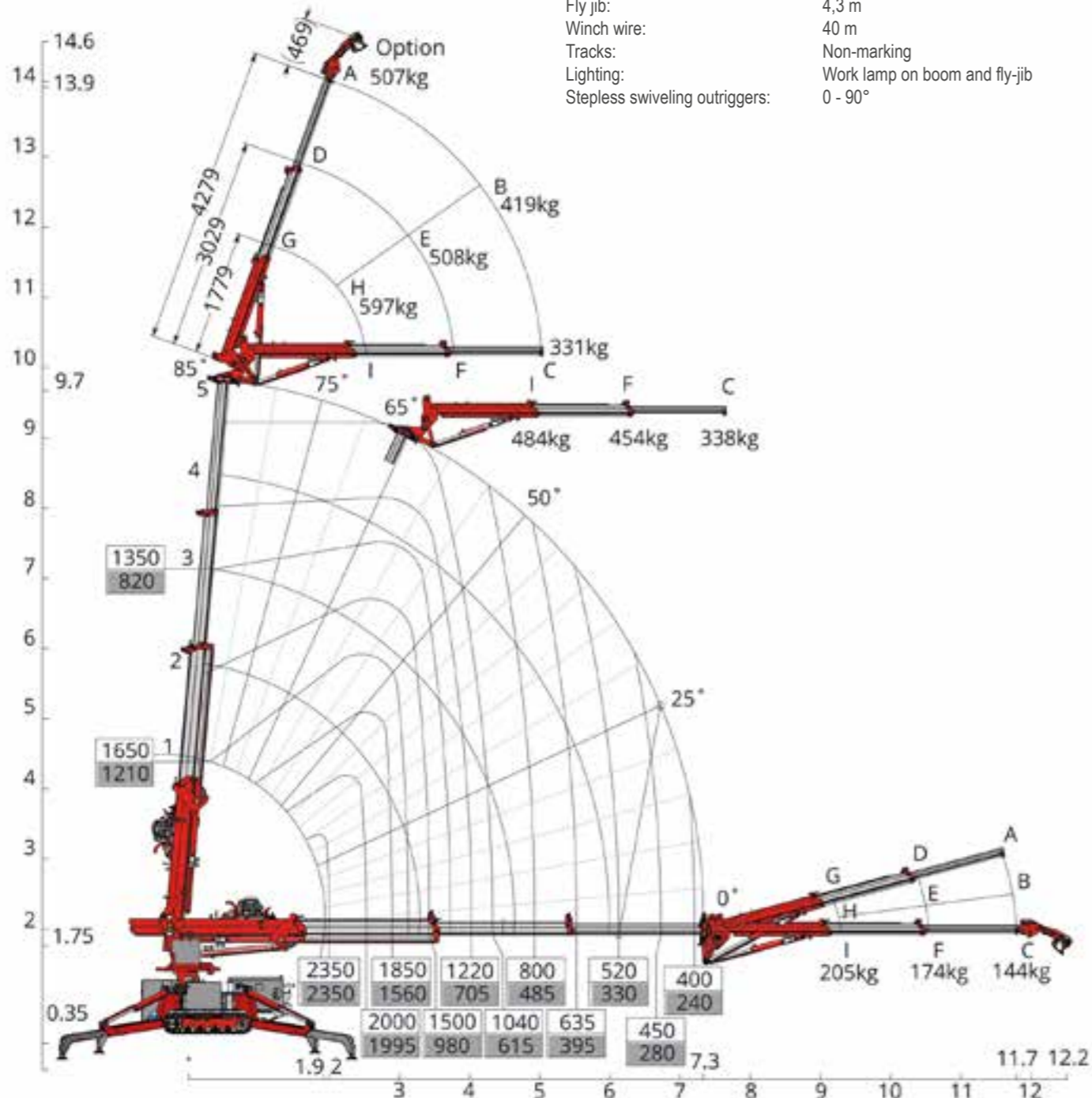

Powerful allround crane C6 compact crane

The C6 is a multifunctional, robust crane with a very simple operation. It lifts more than its own weight. Therefore, this crane is ideal for precise placement of glass and steel beams.

SPECIFIKATIONER

Capacity:	3000 kg
Maximum outreach:	13,7 m x 210 kg
Maximum lifting height:	15,1 and 17 m including options
Dimensions:	L: 3,14 m x B: 0,75 m x H: 1,95 m
Dimensions incl. winch and jib:	L: 3,04 m x B: 0,75 m x H: 1,95 m Total
weight:	2650 kg – and including options 2850 kg
Winch:	1000, 2000 and 3000 kg
Ground pressure:	0,79 kg/cm ²

EQUIPMENT

Electric motor:	230 V
Fly jib:	4,3 m
Winch wire:	40 m
Tracks:	Non-marking
Lighting:	Work lamp on boom and fly-jib
Stepless swiveling outriggers:	0 - 90° Hydraulic expandable outriggers

Can be used with MultiTool.

Available as both a hybrid (diesel + electric) and as a pure Power battery crane.

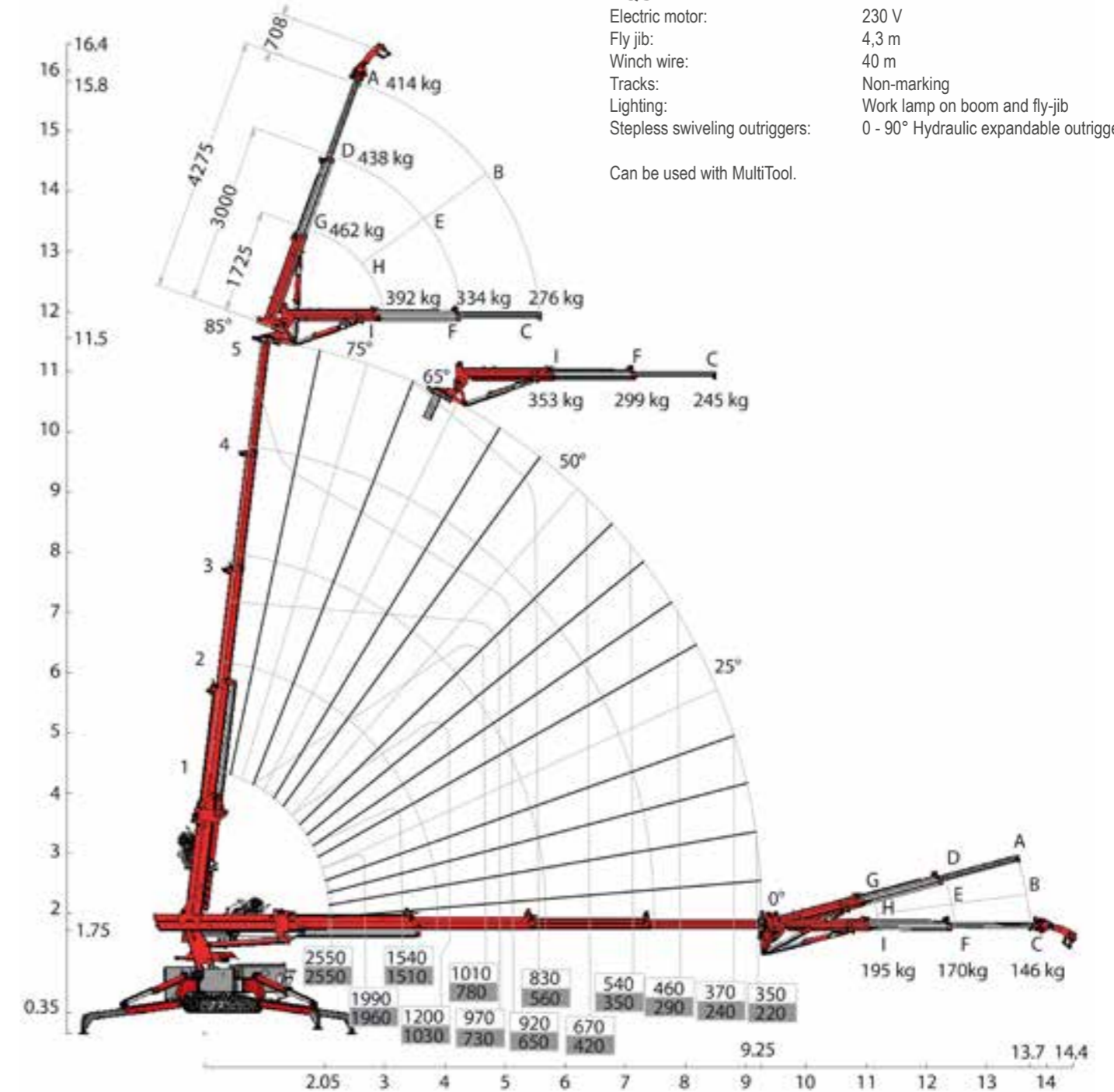

SuperCrane™

HIRE A SAFE CRANE FOR HEAVY LIFTING

We have a modern, comprehensive, and well-maintained crane fleet for hire, consisting of the market's best compact cranes and construction cranes in a wide range of models and capacities.

We exclusively offer the market's best quality. We are, of course, happy to assist you, free of charge, with measurements and solution proposals, ensuring you get the right crane for your task.



Available as both a hybrid (diesel + electric) and as a pure Power battery crane.

Ultra-compact and robust crane C10 compact crane

The Hoeflon C10 Mini Crane has an enormous lifting capacity and three speed levels, making it exceptionally manoeuvrable. It is the perfect choice for heavier tasks within industrial and steel construction.

SPECIFICATIONS

Capacity:	4000 kg
Maximum outreach:	13,7 x 19,8 m including options
Maximum lifting height:	16,3 og 22 m including options
Dimensions:	L: 3,93 m x B: 0,8 m x H: 1,97 m
Dimensions incl. winch and fly-jib:	L: 4,15 m x B: 0,8 m x H: 2,07 m
Total weight:	4000 kg – and incl. options 4700 kg
Ground pressure:	0,79 kg/cm ²

EQUIPMENT

Electric motor:	400 V
Fly jib length:	5 m
Winch wire:	50 m
Tracks:	Non-marking

Can be used with MultiTool.

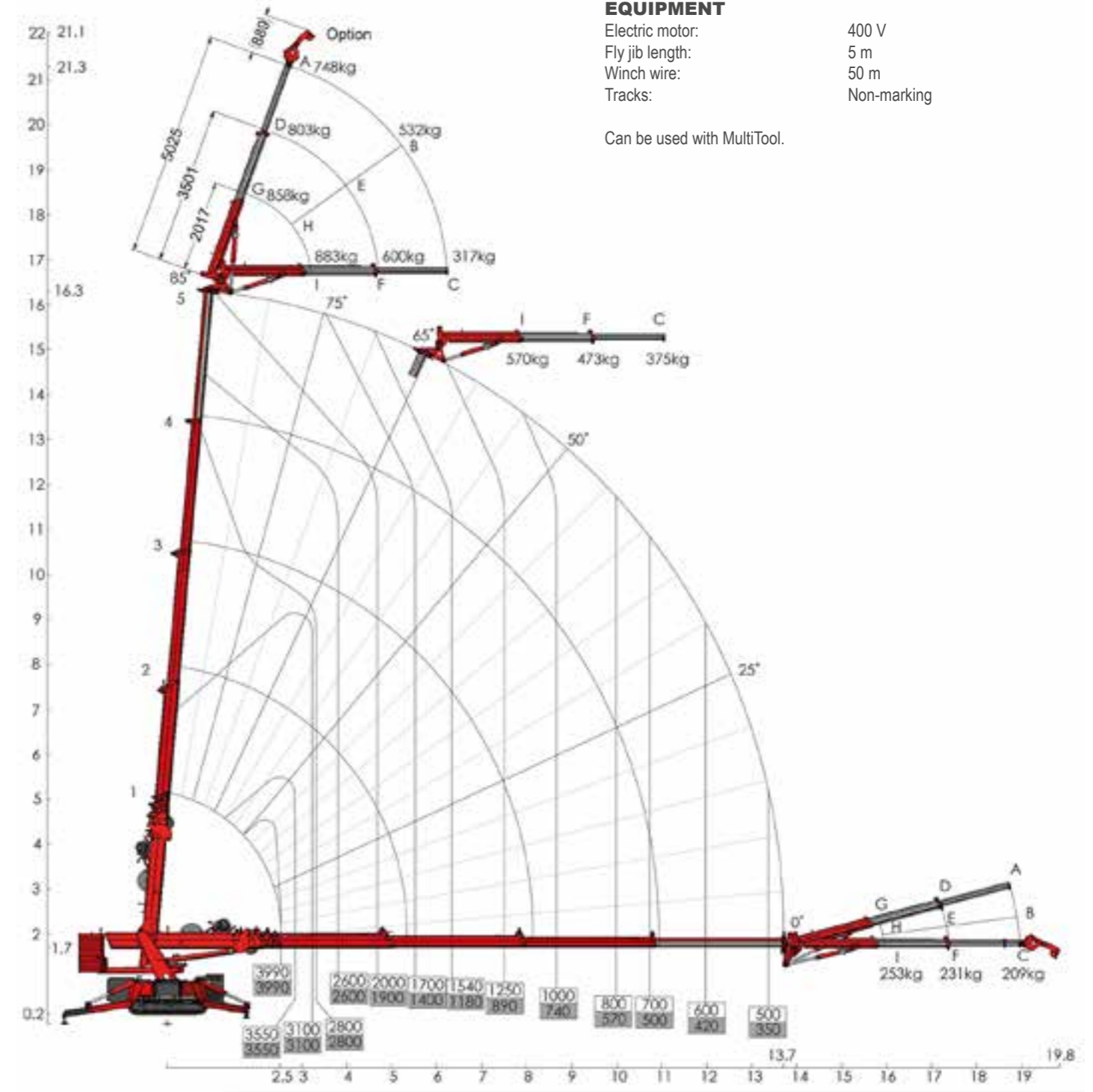

SuperCrane™

Multifunctional, robust and compact cranes



Full lithium driven pick & carry crane C30e compact crane

The Hoeflon C30e is a "State of the art" crane with easy operation and endless possibilities due to its very intelligent software. The C30e has endless rotation, stepless outrigger positioning and various outriggers.

SPECIFICATIONS

Capacity:	9000 kg
Maximum outreach:	12,2 m with fly-jib 20 m
Maximum lifting height:	14,5 m with fly-jib 22 m
Transport dimensions:	3,85 m x 1,2 m x 2 m
Total weight:	8700 kg
Motor:	Electric, lithium battery
Inclination range:	20°
Ground pressure:	0,79 kg/cm ²

EQUIPMENT

Electric motor:	230V, 400V
Fly-jib:	7,5 m
Winch wire:	40 m
Tracks:	Non-marking

Can be used with MultiTool

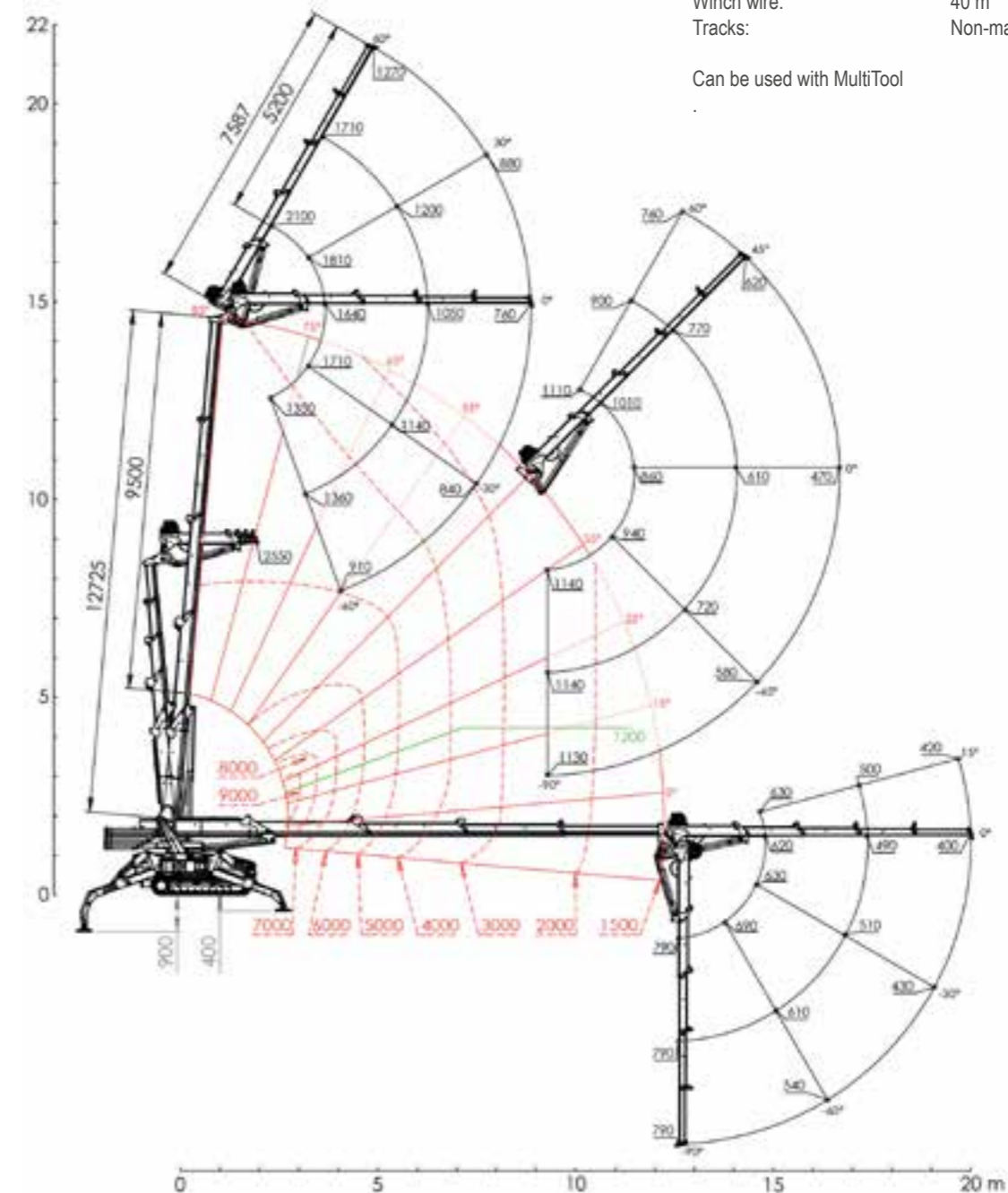

SuperCrane™ SC180

Designed to lift materials and tools up to 180 kg at a height of 60 metres.

The portable folding crane SuperCrane™ SC180 is an innovative and efficient solution for lifting heavy materials that do not fit into an elevator or staircase. The crane easily lifts materials that, due to their dimensions or weight, cannot be lifted in any other way than through the building's facade.

When lifting glass, any sudden impact can break the glass. Therefore, the portable folding crane SuperCrane™ SC180 is also produced in a special model specifically suitable for lifting glass.

SuperCrane™ SC180 Glass is operated with a cable remote control, and the crane model is the same as the SC180. The crane has the same lifting capacity of 180 kg and a lifting height of 60 m.

SuperCrane™ SC180 Glass is equipped with a frequency converter that acts as a total control capacity, both when starting, in soft descent and stopping. After holding the button for either of the two actions - up or down - you will notice that it takes 10 seconds before the motor operates at full capacity. This provides a 10 second reduced speed for the task itself.

Thanks to this variable frequency converter system, you cannot only raise windows but also perform an installation at very low speed levels - without the risk of pulling or banging, preventing the glass from breaking.

When the SC180 Glass model is used in daily work, you as a user can mount glass with millimetre precision.



SuperCrane™ SC180

The SC180 crane is easily set up on balconies as a deck support (soldier). By being tensioned between the floor and ceiling, the ceiling serves as ballast, and the 180 kg can easily be lifted from street level to the floor in question.

If it is not possible to place the crane in a floor setup, it can stand freely with an associated ballast arrangement.

The ballast of the crane in this setup is 360 kg.

The crane is the ideal tool for installation work:

- Ideal for materials such as glass, railings, etc.
- Precision in installation
- Bump-free lifting
- Controlled elevation with remote control

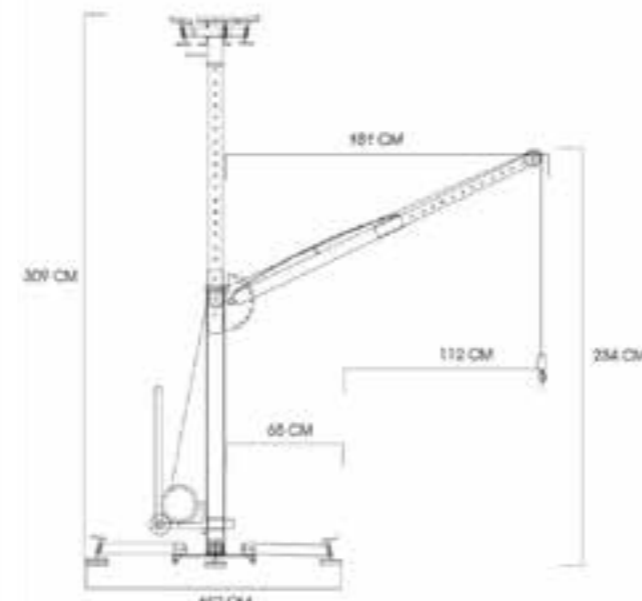
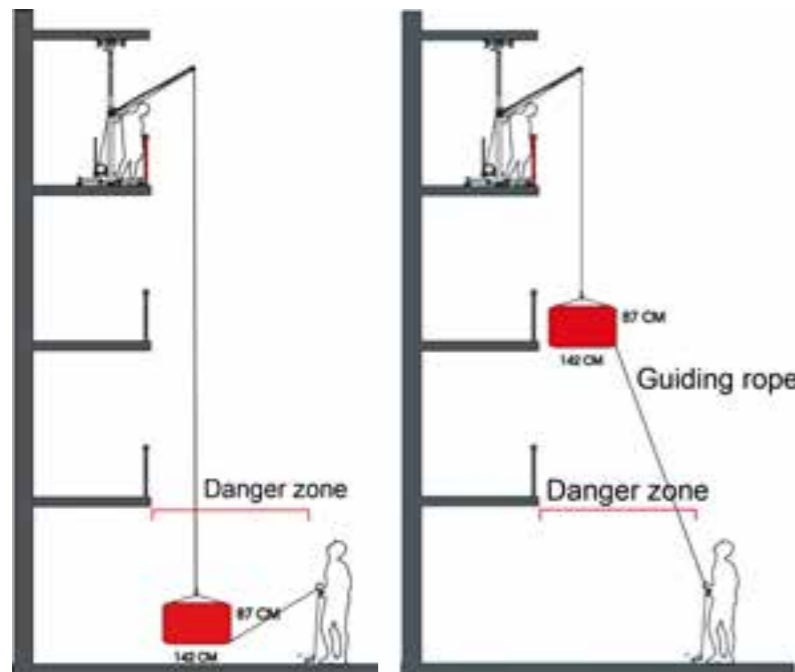

SuperCrane™ XM800

Lifting crane for easy positioning

SuperCrane™ XM800 crawler crane with Pick 'n' Carry function. It is a super flexible mini crane with many possibilities. A small assistant on the construction site to be used for both transport and crane function.

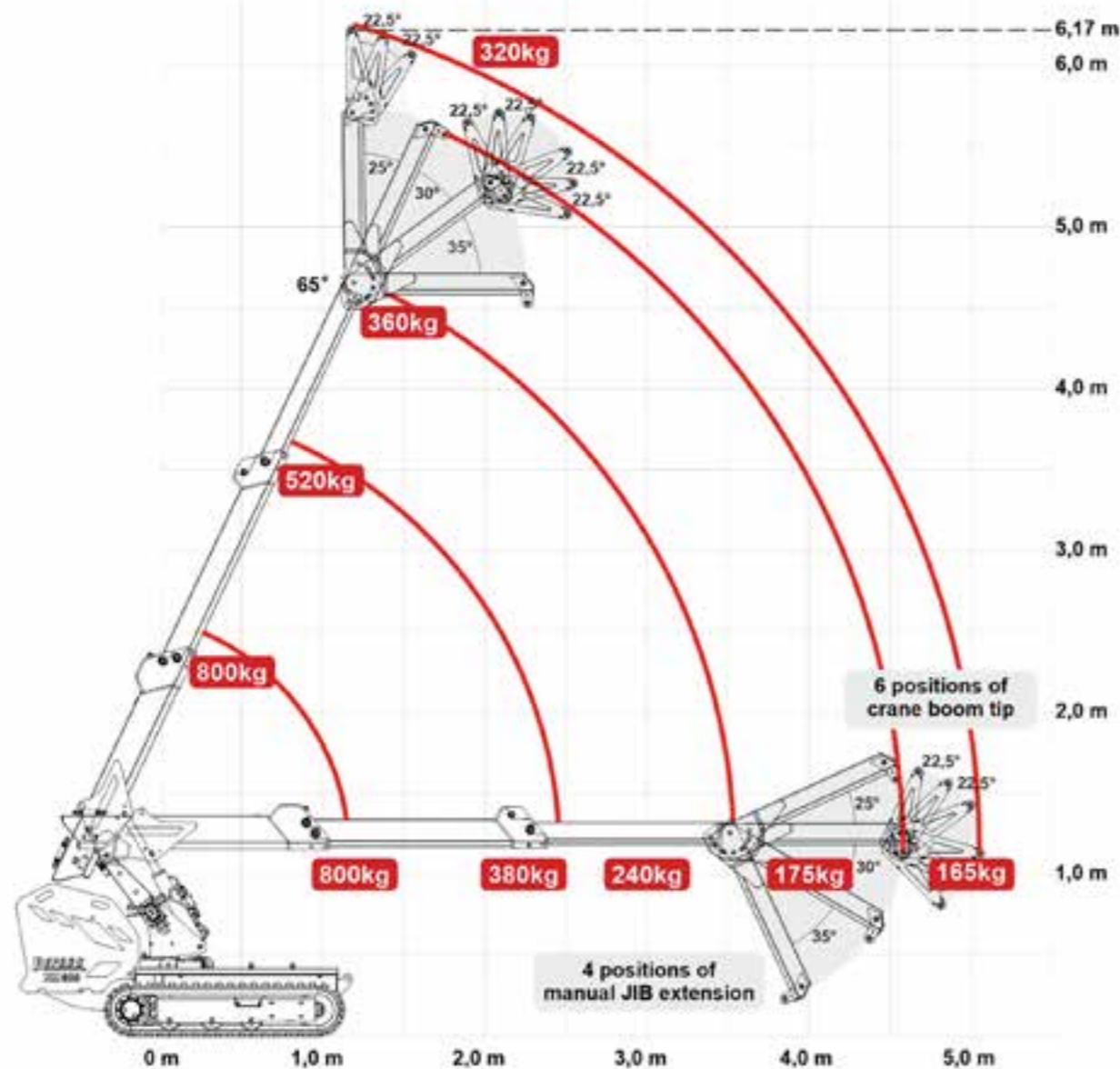

EQUIPMENT

- Winch capacity up to 500 kg
- 2 extension arms
- Detachable loading part
- Non-Marking tracks

TECHNICAL DATA

Own weight:	1100 kg
Length:	230 cm
Width:	78 cm
Height:	145 cm

FEATURES

- Pick 'n' Carry function
- Extension tracks
- Remote control

All configurations of XM800 are equipped with a hook, which can be re-mounted on extra equipment if necessary.

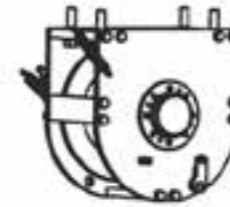

Winch



Crane boom tip



Manual JIB extension

SPECIFICATIONS

Maximum lifting capacity:	800 kg
Transport of mini crane:	By car up to 3.5 t
Anti-overload system:	Yes
Hydraulic extensions:	2
Maximum vertical reach:	6,17 m Maximum horizontal reach: 5,0 m
Hydraulic slewing range:	Rotation to the left and right 25° (all in all 50°)
Remote control:	Both for driving and operation of the crane.
Propulsion:	Lithiumion batteries (possible direct connection to 230V/110V)



Remote control for SuperCrane™ XM800

Remote control with control for both driving and operation of the crane, including start-stop motor.



SuperGlassHandling™

At Preston Rentals, we offer nationwide hire of all types of glass suction cups and glass lifters with vacuum suction and lifting yoke, allowing you to carry out your glass suction and vacuum suction tasks safely and efficiently.

We can quickly adapt to your specific task. We are happy to combine the crane task, including both glass suction and transportation. Of course, we deliver on time and at competitive prices.

Vacuum yokes are also an efficient gripping equipment for tasks involving airtight items:

- Transport of glass
- Glass lifting and installation
- Lifting of sandwich panels
- Lifting of fibre concrete and balcony bases
- Other tasks involving glass suction and vacuum suction



Lifting and transport with vacuum suction

320 KG SPIDER SUCTION

This suction cup has 4 suction cups arranged in a square and has a lifting capacity of 320 kg. It can be supplied with a remote control.

The suction cup is particularly suitable for lifting windows with glazing bars in the middle. Additionally, extensions can be attached to the cups, allowing the suction cup to be moved away from the suction surface. This is an advantage when installing windows where the glass is set deep in the frame or in sliding doors where the window is offset.

The suction cup can also be fitted with cups for lifting sandwich panels. With extension arms, stability is increased when lifting larger items.



320 KG REACH SUCTION

The glass lifter/reach suction x 4 for crane hook can lift up to 320 kg. This vacuum suction has 4 pieces of 11" suction cups in a row with a very low net weight of only 44 kg.

The reach suction is the perfect vacuum suction for narrow windows. The vacuum suction can both rotate and tilt manually.

This suction cup has detachable suction cups for increased flexibility and installation of very small windows/items.



135 KG 2 SUCTION CUP

This suction cup has 2 suction cups and a lifting capacity of 135 kg. The suction cup is particularly suitable for lifting small pieces of glass and windows.

600 / 800 / 1000 KG HOEFLON SUCTION

The Hoeflon Vacuum Suction is a multifunctional glass lifter of premium quality, with outstanding fit and finish at a highly competitive price.

Unique features:

- Compact base unit for glass with small dimensions
- A spider-shaped design with large spread providing greater ease of installation, speed, and safety with large glass
- Lightweight design

The standard version includes:

- Remote control
- Transport trolley
- Long lifting arm
- Short lifting arm
- Replaceable battery system including an extra battery
- Protective covers for suction cups

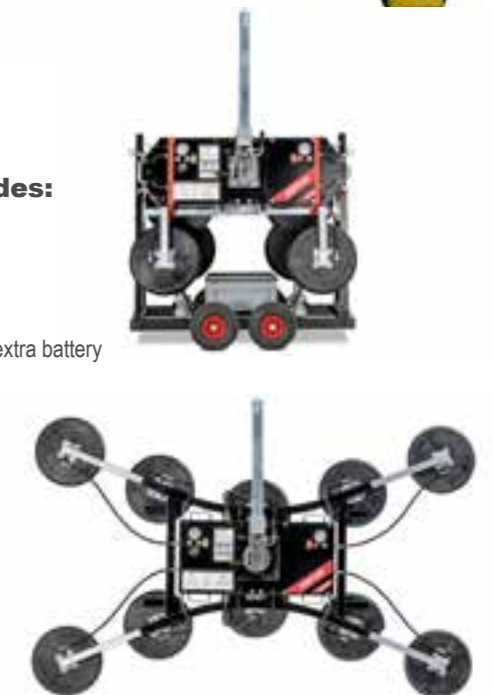
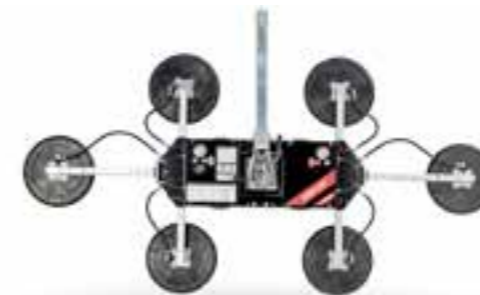

VIAVAC

Lifting - rotating - tilting

With VIAVAC vacuum lifters, you can install all types of panels.

Benefits:

- Speeds up installation
- Reduces labour costs
- Improves working conditions
- Prevents damage
- Complies with all safety standards

*No panel tasks are the same.
Contact us, and we'll assist
you with suggestions for
your specific task.*



CladBoy Kompakt

- the practical unit for wall panels.



CladBoy Kompakt

- the practical unit for wall panels.
Also suitable for sandwich roof panels.



CladBoy Kompakt

- easily rotates long roof panels.



SuperGrab™ BX1000

Proven and robust technology that minimises heavy lifting and optimises the workflow in the installation of I-beams, steel beams, and for example circular objects such as downpipes, drainpipes etc.

Heavy and strenuous work made easy

No more pulleys, hoists, and chains when lifting beams and pipes in your installation work. The SuperGrab™ BX1000 can be easily mounted on one of our SuperCrane™ C6 or C10.

What can SuperGrab™ BX1000 do?

The SuperGrab™ BX1000 has a capacity of 1000 kg but works in conjunction with the crane's lifting capacity and operating diagram. The SuperGrab™ BX1000 can lift items up to 1000 kg - with adjustable manoeuvring, it lifts and rotates items both vertically and horizontally. This optimises the time processes during installation and saves valuable crane time.

Easy and safe operation

With the crane's intuitive remote control, items are lifted easily and securely placed in the right position.



SuperGrab™ BX1000 for easy positioning

The **SuperGrab™ BX1000** industrial manipulator for positioning pipes and beams can perform three hydraulic functions: gripping, rotating, and tilting.

The SuperGrab™ BX1000 is attached to the crane and controlled via the crane's remote control. It is indispensable in the construction industry, both for new construction and renovation.

The SuperGrab™ BX1000 enables the unloading and stacking of heavy poles, beams, pipes, as well as their precise vertical and horizontal positioning during installation.

- Grip, rotate, and tilt the load
- Compatible with multiple machines
- Precision work vertically and horizontally
- Eliminates heavy lifting
- Ideal for pipe installation and beam mounting



SPECIFICATIONS

Maximum load capacity:	1000 kg
Load size:	100 – 300 mm
Jaw distance:	1445 mm
Number of jaws:	2 pieces
Weight:	app. 320 kg
Built-in hydraulic rotator	
Locking force	23kN
Non-return valve:	Yes

Electric change valve for switching to three circuits
(functions for cranes with two hydraulic valves available).

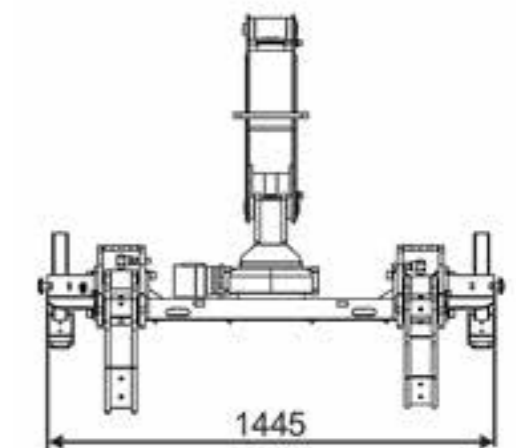

For more information, please contact us at phone: +45 31 640 550 or e-mail: mail@prestonrentals.dk

MultiTool

Mount your crane for all types of tasks



MultiTool offers a combination of functions as an extension to the Hoeflon compact cranes. With MultiTool, most types of beams, pipes, sheets of glass and pallets can be easily put in the right place. If your task requires a completely special and unique fittings, this can be designed.

MultiTool has been developed in close cooperation with users from the field. This results in products that are in a class of their own. The many functions and details provide the user with many new possibilities and conveniences in daily use.

Unique features:

- Various attachments
- Compatible with the Hoeflon C6, C10, and C30e cranes
- Outstanding rotational axes

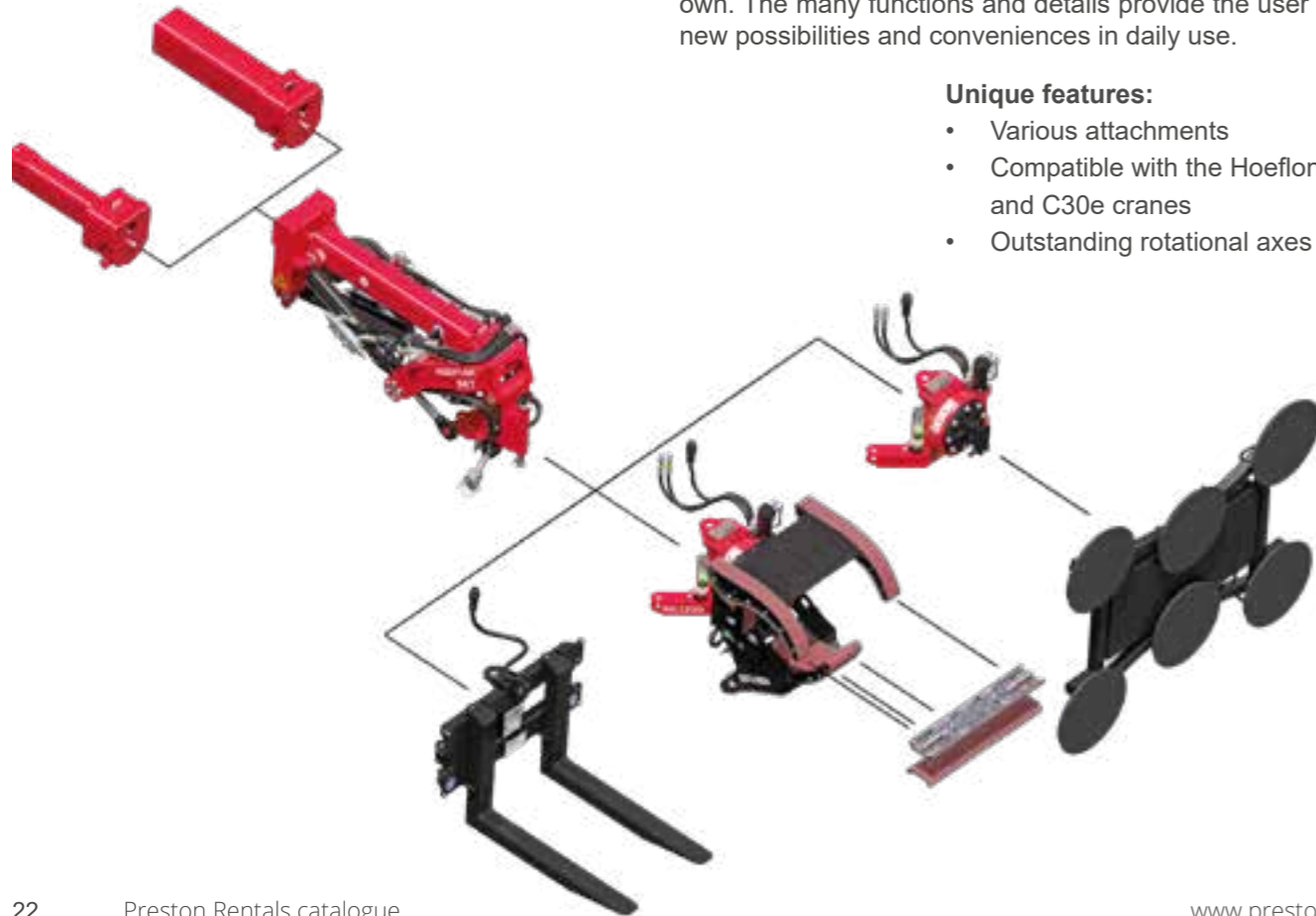

MULTICLAW

Multiclaw with clamping jaws for clamping and moving beams, etc. These clamping jaws can lift pipes with a diameter of up to 500 mm.

The beam clamp consists of a narrow jaw with a single clamping element and a wide jaw with a double clamping element. Objects of various shapes can be clamped in these jaws.

Removable clamping plates increase the clamping surface and allow clamping an object parallel to the jaws. Without the clamping plates, it is also possible to clamp a plate or a beam on the outside of the clamping jaw.

SPECIFICATIONS:

Weight of Multiclaw including clamping jaws:	340 kg
Weight of clamping jaws:	188 kg
Pipe diameter, beam clamp:	500 mm
Maximum lifting capacity of beam clamp:	1250 kg
Lifting capacity, eye:	2000 kg



MULTIVAC

The glass suction lifter is a vacuum lifter for positioning and moving medium to large, flat, and non-porous sheets of glass.

Glass suction lifters are attached to the MultiTool via an adapter.

This unit has the same freedom of movement as the beam clamp (Multiclaw).

SPECIFICATIONS:

Weight, MultiTool including glass suction lifter:	198kg
Machine weight:	85 - 110 kg
Maximum lifting capacity:	1000 kg
Lifting capacity, eye:	2000 kg
Type of glass suction lifters:	C600, S600, S800, S1000



MULTIFORKS

The MultiForks pallet fork frame can be mounted on the MultiTool for lifting and moving pallets.

The long reach of the compact crane allows for placing pallets in high and hard-to-reach places.

MultiForks can only be used with the C30e.

SPECIFICATIONS:

Weight of pallet fork frame including tines:	64 kg
Weight, MultiForks including pallet fork frame:	216 kg
Maximum lifting capacity:	2000 kg
Fork length:	800 mm



Crane Accessories

Hoeflon Jib transporter

Unique features:

- Multifunctional
- Suitable for C4, C6, C10, and C30
- Easy to disassemble
- Lightweight - 45 kg
- Compact storage

Net weight: 45 kg
Dimensions: 1115 x 770 x 478 mm



Hoeflon lifting beam

The all-rounder beam with unique features for compact cranes:

- Low weight
- Compact dimensions
- Flexible adjustability
- High capacity

Net weight: 45 kg
Capacity: 1,2 - 6 ton
Dimensions: 1250 x 169 x 274 mm



Plasterboard clamp

The plasterboard clamp is designed for lifting as well as vertical transport of wood, chipboards, and plastic sheets.

The clamp is attached to the board using a handheld handle. The jaw, which has a protective lining, grips securely when the lifting begins.

Capacity: 400 - 750 kg.



Beam Grab

The Beam Grab has a load capacity of 1,000 - 10,000 kg.

- Robust steel construction
- Compact size with low weight
- Low built-in height
- Super-fast adjustment on any flange
- It is easy to use and can be used for mounting on
- Beams for the installation of hoists, etc., and for lifting beams.
- Several types are available, e.g. with shackle in suspension and other hanging options.



Kerbstone Clamp

The Kerbstone Clamp can be installed on cranes and mini excavators. It can be used for regular/square stones or foundation blocks.

Maximum lifting capacity: 200 kg
Capacity: 100 - 300 mm
Width of rubber pads: 240 mm
Own weight: 12 kg
LxHxB: 60 x 60 x 24 cm



Chains, Straps, Shackles

At Preston Rentals, we offer various types of lifting equipment for your task. This could include chains with shortening hooks or flat straps. Through close dialogue, we determine the right assortment of lifting gear for your task.



The following equipment is always included for free when hiring our cranes:



2 pcs. of straps WLL 1 ton, 1 mtr. (Violet)

2 pcs. of straps WLL 1 ton, 2 mtr. (Violet)



4 pcs. of H-Shackle WLL 2,0 ton, 1/2"



Intermediate piece for hook with 4 wire cutting



4 tons crane hook with swivel (Brand: Gunnebo)



H-Shackle with lock WLL: 3.25 tons



Wire steering



Wire wheel for cutting wire (2 pcs.)



Insertion piece to be used in main arm

Do you need crane work with a compact crane?

We offer crane services performed by experts and specialists for lifting your materials or installation tasks.

We specialise in hoisting all types of construction materials and can assist you with everything from small tasks to window installation.



SuperElevate™

Transport Carrier Hoeflon TC1 - compact, strong and robust

The Hoeflon TC1 transporter is the solution for the horizontal transport of long, heavy construction materials and equipment on a project site. It is a battery-powered transport platform with endless possibilities.

The TC1 platform is equipped with a swivel crane with a rotating platform that can rotate infinitely. This provides significant flexibility in transporting beams, stairs, etc. The TC1 transporter has a low centre of gravity and precise manoeuvrability. It easily moves around different ground heights and uneven terrain, even when loaded.

TC1 can also navigate very steep inclines. It is an ideal machine in combination with Hoeflon cranes.

It is designed with various stick holes, extension arms, and lashing, ensuring that the cargo remains stable during transport.

This also makes it easier to construct custom-designed racks, glass trestles, and the like. Our transporter, Hoeflon TC1, can pass through any door. No matter where your goods are, our little assistant transporter will get there.



SPECIFICATIONS

Capacity:	1200 kg
Net weight:	500 kg
Dimensions (lxbxh):	1450 x 800 x 420 mm
Power:	Electric
Power supply:	Battery pack
Charger:	230V - 50Hz
Charging time:	13 hours
Ground pressure:	0,15 kg/cm ²
Maximum speed:	2,2 km/t
Speed regulator:	Proportional drive
Maximum tilt angle:	25°
Maximum tilt angle:	20°
Loading platform (lxb):	1340 x 730 mm
Type of platform:	Rotatable



Available in various sizes - please contact us to learn more.

TC1 in brief:

- Compact, strong, and robust
- Highly precise manoeuvrability
- Easy attachment of load items
- The platform is movable/rotatable
- Silent due to the electric drive

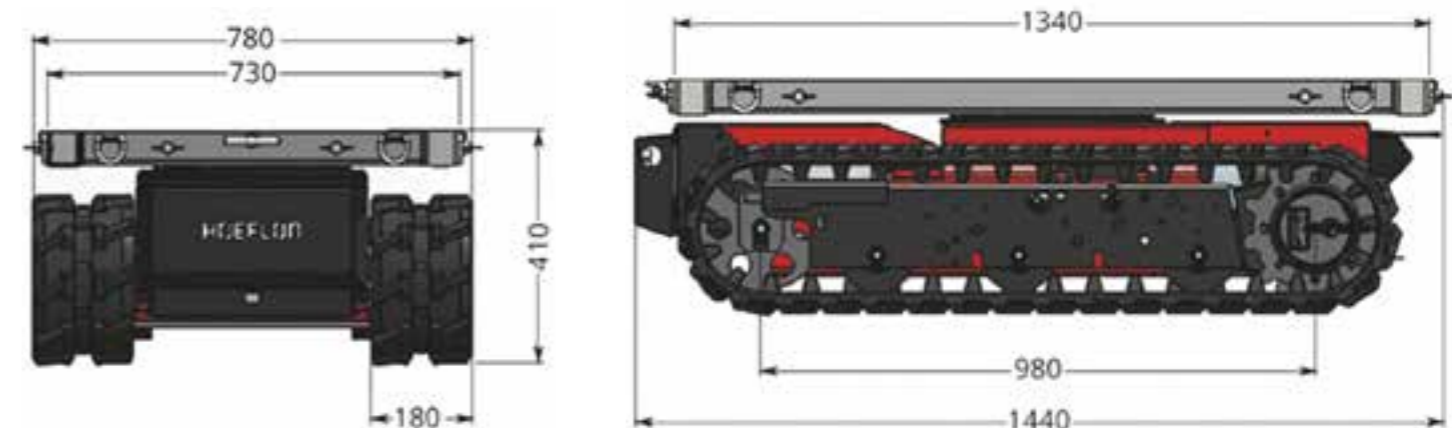

Lumberjack

Efficient, reliable, and innovative lifting systems

Available in models:

- MiniMax L3
- MiniMax L5
- Lumberjack L20-3



Lumberjack is a proven and robust technology in a new design. Radio-controlled precision levelling reduces installation time and increases safety.

We hire and deliver efficient, reliable, and innovative Lumberjack lifting systems to facilitate material handling and improve profitability, primarily within the building and construction sector.

Lifting, levelling, and turning materials on the construction site can be a time-consuming and challenging task. The Lumberjack's remote-controlled levelling hoists make this work much more efficient and safer. All types of items that require accuracy and precision are easily navigated into place, reducing costly crane time and waiting time.

We hire the Lumberjack remote-controlled levelling hoists with a lifting capacity of up to 20 tons. All lifting beams have robust and well-proven technology, as well as reliable electric operation, ensuring they function in all weather conditions. The hoists are manoeuvred smoothly with user-friendly and classified remote controls.

We are happy to provide free advice and guidance so you can solve your task most effectively.



MiniMax L3

The MiniMax L3 remote-controlled precision levelling reduces your installation time and increases safety on the construction site.



The MiniMax L3 lifting yoke levels and handles building materials easily and safely with a simple press of a button. It ensures that you reduce costly crane time and waiting time. The lifting beam handles both light and heavy objects weighing up to 3 tons.

With its robust, proven technology and reliable electric operation, the MiniMax L3 can work in temperatures ranging from -20°C to +40°C. The lifting beam is easy to clean due to its robust housing and IP65-classified electrical system.

The MiniMax L3 requires minimal service - only cleaning and battery charging. The battery status is displayed. Under normal use, it is sufficient to charge the battery once a week. The MiniMax L3, with its user-friendly IP67-classified remote control, is easy to operate.

SPECIFICATIONS

Lifting capacity:	Max 3 tons
Levelling Force:	Max 500 kg
Max levelling stroke length:	3 m (1.5 m in both directions)
Levelling speeds:	2
Max chain angle:	60° with a 3-ton load
Total chain length:	3 m
Chain dimensions:	30.5 x 10 mm
Weight:	126 kg (Including chain and hooks)
Height:	638 mm
Width:	503 mm
Depth:	495 mm

Control system

Radio range:	100 m line of sight
Electric motor voltage:	24 VDC
Power consumption in hibernate mode:	50 mA
Max continuous power consumption:	24 A
Peak power consumption:	30 A

Certification: CE-marked product

Environmental Requirements

Operating temperature:	-20°C – +40°C
Storage temperature:	-20°C – +45°C
Relative humidity, RH:	0 - 90% during storage

Optional Accessories

- Protective cover
- Chain kits in other lengths
- Additional batteries
- Transport packaging



MiniMax L5

The MiniMax L5 is a lifting yoke that, by utilising both new and proven technology, levels and handles loads efficiently and safely with high precision.



The MiniMax L5 lifting yoke can handle both light and heavy objects up to 5 tons. It maximises efficiency, reduces assembly time, and increases safety with precise and comprehensive levelling and handling of various types of objects. The MiniMax L5 has a reversible stroke length of up to 1.5 metres per hook in the standard version.

With a press of a button, the MiniMax L5 levels and handles its objects easily and safely, reducing costly crane time and wait time. A robust and proven technology, along with a secure electrical operation enable the lifting yoke to operate in all weather conditions from -20 to +40 degrees Celsius in demanding environments.

The robust, durable, and reliable housing, plus the IP65-classified electrical system, makes the lifting yoke easy to clean. In addition to cleaning, battery charging is the only thing to consider. The battery status is indicated on the yoke, and with normal use, one charge per week is sufficient.

The MiniMax L5 is used as a snatch block. With a user-friendly and IP67-classified remote control, the MiniMax L5 is manoeuvred smoothly. The chain wheel is disengaged with the remote control for free-running chain with the same function as a snatch block. A longer chain package can be ordered as an option.

SPECIFICATIONS

Lifting capacity:	Max 5 tons
Levelling force:	Max 750 kg
Max levelling stroke length:	3 m (1.5 m in both directions) in the standard version
Levelling speed:	2
Max. chain angle:	60° at 5 tons load
Total chain length:	3 m in the standard version
Chain dimensions:	30.5 x 10 mm
Weight:	approximately 130 kg (Including chain and hooks)
Height:	638 mm
Width:	503 mm
Depth:	495 mm

Control System

Radio range:	100 m with a clear view
Motor voltage:	24 VDC
Power consumption in hibernate mode:	50 mA
Max continuous power consumption:	24 A
Peak power consumption:	30 A
Certification:	CE-marked product

Environmental requirements

Operating temperature:	-20°C – +40°C
Storage temperature:	-20°C – +45°C
Relative humidity, RF:	0 - 90% during storage

Optional accessories

- Protective hood
- Chain kit in other lengths
- Additional batteries
- Transport packaging.



Lumberjack L20-3

A remote-controlled levelling hoist with proven and robust technology



The Lumberjack L20-3 is based on a proven and robust technology in a new design, which, with its radio-controlled precision levelling, reduces installation time and increases safety. This radio-controlled levelling hoist is ideal for lifting items of all kinds that require accuracy and precision to navigate into place.

SPECIFICATIONS

Lifting capacity:	Up to 20 tons
Chain wheel traction:	Chain wheel traction
Levelling length:	6 m (3 m in both directions)
Levelling speeds:	2
Chain angle:	Up to 80°
Point of lubrication:	1
Total chain length:	Up to 6 m
Chain dimensions:	60.5 x 20 mm
Own weight:	Approx. 395 kg
Height:	1050 mm
Width:	712 mm
Depth:	623 mm

Control system

Radio range:	100 m with a clear view
Motor voltage:	24 VDC
Power consumption in hibernate mode:	50 mA
Continuous power consumption:	60 A – 1,400 watts
Peak power consumption:	100 A – 2,400 watts

Certification:

CE-marked product

Environmental requirements

Operating temperature:	-20°C – +40°C
Storage temperature:	-20°C – +70°C
Relative humidity, RH:	0 - 90% during storage

Optional accessories

- Protective cover
- Chain kits in other lengths
- Extra batteries
- Transport packaging

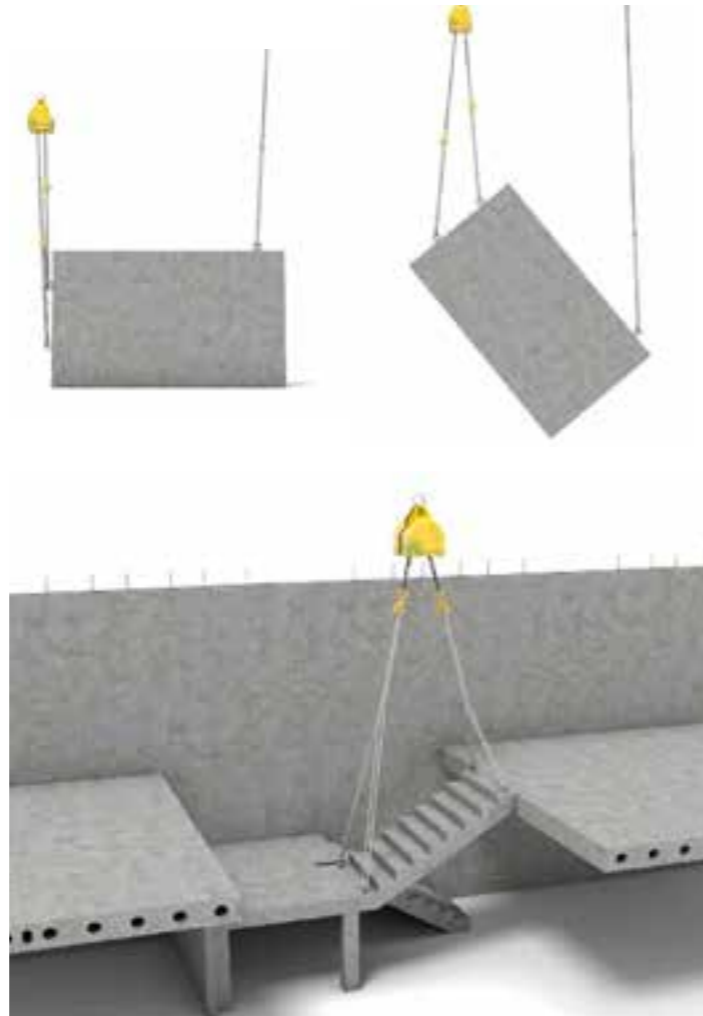

The Lumberjack L20-3 makes heavy and cumbersome levelling work easy:

- Remote levelling of loads up to 20 tons
- Built-in battery = no need for power or hydraulics
- Intuitive operation
- Is delivered directly to the construction site and ready to use
- Positions elements with millimetre precision
- Remote control with a range of 100 metres and 2 speed levels



SuperDeck®

Patented “drawer-like” loading platform system
- easy to install and use



SuperDeck®



SuperDeck® is available in four sizes

SuperDeck® 2.2



Dimensions
 Length: 8500 mm
 Width: 2200 mm
 Height: 1202 mm
 TARE
 Weight: 2500 kg
 Capacity – max load in SuperDeck® 5000 kg.

SuperDeck® 2.6



Dimensions
 Length: 8500 mm
 Width: 2600 mm
 Height: 1202 mm
 TARE
 Weight: 2800 kg
 Capacity – max load in SuperDeck® 5000 kg.

SuperDeck® 3.2



Dimensions
 Length: 8500 mm
 Width: 3200 mm
 Height: 1202 mm
 TARE
 Weight: 3000 kg
 Capacity – max load in SuperDeck® 5000 kg.

SuperDeck® 4.2



Dimensions
 Length: 8500 mm
 Width: 4200 mm
 Height: 1202 mm
 TARE
 Weight: 3500 kg
 Capacity – max load in SuperDeck® 5000 kg.

Rear prop option now available

SUPERDECK®	2.2	2.6	3.2	4.2
MAX. LOAD CAPACITY	5000kg	5000kg	5000kg	5000kg
TARE WEIGHT	2500kg	2800kg	3000kg	3500kg
MAX. OUTBOARD LENGTH	5250mm	5250mm	5250mm	5250mm
WIDTH OF DECK	2200mm	2600mm	3200mm	4200mm
PROP OR BOLT DOWN OPTION	3	3	3	3

SIDE ELEVATION
 Dimensions: 2235 (height), 4000 (inboard), 4500 (outboard), 8500 (total length), 1202 (height).

FRONT ELEVATION
 Dimensions: 2200, 2600, 3200, 4200 (widths).

A new method for hassle-free handling of materials on the construction site

Loading and unloading materials at a construction site are both time-consuming and risky work. Streamlining this process provides immediate time savings in production. That's why PRESTON RENTALS® is now introducing a brand-new method that simplifies and enhances logistics.

This patented innovation is designed to simplify the handling of materials, especially on multi-level construction sites. The SuperDeck® offers a "drawer-like" loading platform system that slides, significantly enhancing safety and reducing crane operating time.

Easy to set up in just a few minutes

Instead of using traditional scaffolding and loading towers with material lifts, the PRESTON RENTALS® SuperDeck® principle is based on so-called sliding platforms that are easily mounted on the floors where materials need to be lifted in or out.

The sliding platform is easy to assemble and is lifted into place with a crane

In minutes, the sliding platform is securely fastened between the floor and ceiling using four stabilisers. The deck is extended, allowing materials to be lifted into the platform

by a crane, making both the construction material and machines accessible on the floor.

The sliding platforms can be installed on each floor and can be integrated with scaffolding. The sliding platform is available in four sizes and has a load capacity of five tons.

In Australia, where the system has been used for a long time, it has become evident that on SuperDeck® construction projects, crane efficiency has increased by 50%. Larger and heavier materials can be lifted with an increase of 71.4 percent. It has been possible to reduce lost working time related to waiting for materials through traditional material transport by 35.7%.

Overall, time used for the handling of materials has been reduced by up to 14.3%, and unforeseen delays from subcontractors have been minimised by up to 28.4%.



"This is a truly significant innovation for logistics work on a construction site. Everyone knows that the lifting of materials and the handling of heavy items in elevators and on scaffolding is complex and poses a safety risk today. With the SuperDeck®, you save both time and increase safety.

Additionally, the payload can be increased, and the system can be integrated with scaffolding.

Another advantage is that materials can be loaded directly from the truck onto the sliding platform at the construction

site, saving a considerable amount of time. A third interesting application is to use the sliding platforms for unloading demolition material.

Today, more and taller buildings are being erected in cities with multiple floors, often in dense urban areas with minimal space; here, the SuperDeck® is perfect for handling materials".

Martin Bo Bojesen
 Managing Director, Preston Rentals

SuperPropping™

Flexible and adjustable pillars

The Multiprop is well known and accepted in the construction industry. It has been used for many years, on many building and construction sites, and in many different applications.

SuperPropping™ provides a simple, fast, lightweight and flexible method of providing temporary support where needed.

SuperPropping™ has the ability to be arranged in a tower of four to enhance formwork systems to cope with larger concrete structures.

SuperPropping™ also has a range of attachments to carry beams and other structural items.

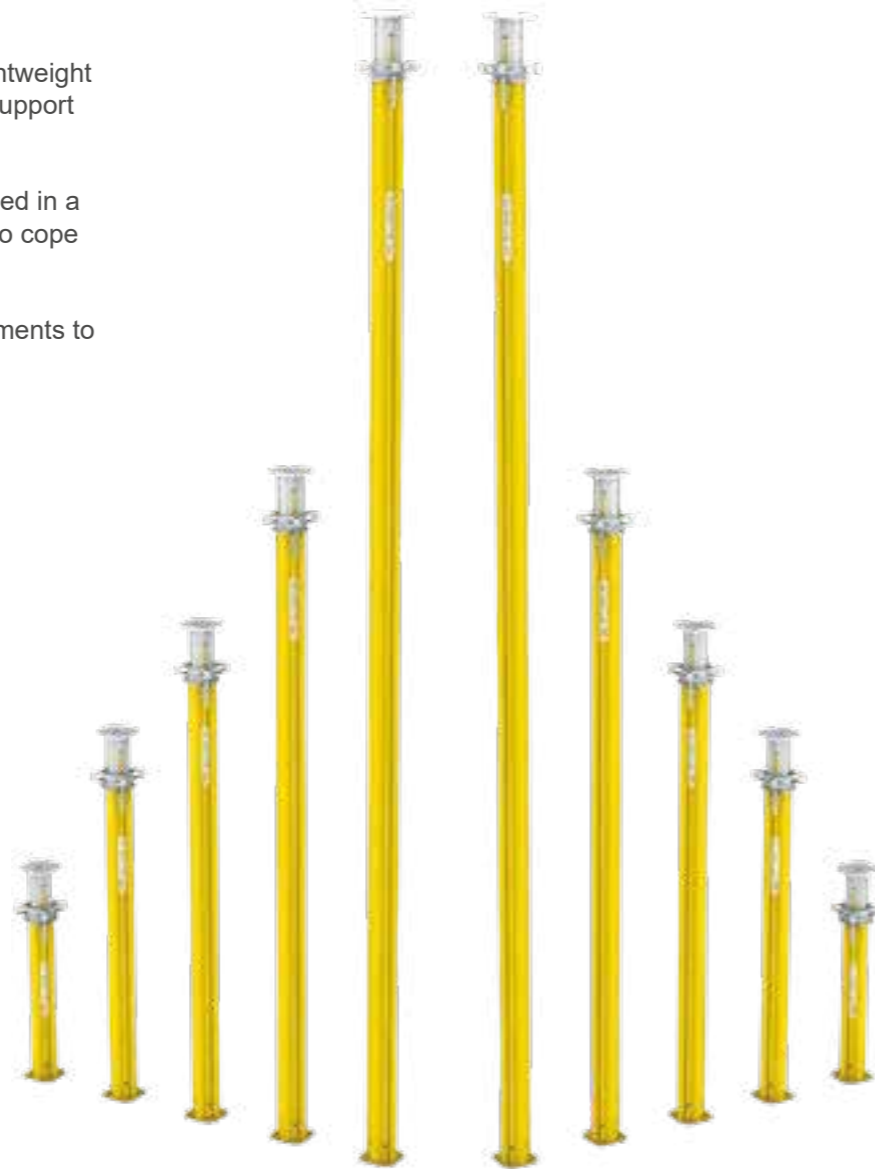

SPECIFICATIONS

MP250

Dimensions:
Length: 1450 – 2500 mm
Weight: 15,6 kg

MP350

Dimensions:
Length: 1950 – 3500 mm
Weight: 19,7 kg

MP480

Dimensions:
Length: 2600 – 4800 mm
Weight: 25,0 kg

MP625

Dimensions:
Length: 4300 – 6250 mm
Weight: 34,8 kg

Lifting Capacity:
7,5 tons at 1450 mm
6,2 tons at 2500 mm

Lifting Capacity:
9,0 tons at 1950 mm
4,4 tons at 3500 mm

Lifting Capacity:
7,3 tons at 2600 mm
2,6 tons at 4800 mm

Lifting Capacity:
4,5 tons at 4300 mm
2,1 tons at 6250 mm

Permissible Prop Load (kN) according to the Type Test

Extension Length (m)	MP 250 L - 1.45 - 2.50 m		MP 350 L - 1.95 - 3.50 m		MP 480 L - 2.60 - 4.80 m		MP 625 L - 4.300 - 6.25 m	
	Outer Tube Bottom	Inner Tube Bottom	Outer Tube Bottom	Inner Tube Bottom	Outer Tube Bottom	Inner Tube Bottom	Outer Tube Bottom	Inner Tube Bottom
1.45	73.3	76.2						
1.50	73.3	76.2						
1.60	73.3	76.2						
1.70	73.3	76.2						
1.80	71.7	76.2						
1.90	68.6	76.2						
1.95	67.0	76.2	88.3	87.4				
2.00	65.4	76.2	88.3	87.4				
2.10	63.8	74.6	83.0	87.4				
2.20	62.2	73.0	77.7	87.4				
2.30	61.1	70.5	72.9	86.6				
2.40	60.6	67.0	68.6	85.1				
2.50	60.0	63.6	64.4	83.5				
2.60			61.9	80.7	85.9	71.4		
2.70			59.3	77.8	81.2	71.1		
2.80			57.5	74.9	76.5	70.8		
2.90			55.7	71.9	71.8	70.4		
3.00			54.3	68.3	67.1	70.1		
3.10			52.9	64.6	63.0	69.4		
3.20			51.4	60.0	58.9	68.6		
3.30			49.8	55.4	54.8	67.9		
3.40			46.4	50.3	52.5	66.2		
3.50			42.9	45.1	50.2	64.5		
3.60					47.9	62.8		
3.70					46.0	58.6		
3.80					44.2	54.4		
3.90					42.3	50.2		
4.00					40.4	46.9		
4.10					38.5	43.7		
4.20					36.6	40.4		
4.30					34.8	38.2	56.2	44.6
4.40					32.9	36.0	54.7	44.6
4.50					31.1	33.7	53.1	44.6
4.60					29.3	31.5	50.9	43.8
4.70					27.4	29.3	48.8	43.0
4.80					25.6	27.1	46.4	42.1
4.90							43.8	41.2
5.00							41.2	40.3
5.10							38.6	38.8
5.20							36.1	37.3
5.30							33.8	35.9
5.40							31.9	34.5
5.50							29.9	33.1
5.60							28.4	31.6
5.70							26.9	30.1
5.80							25.5	28.6
5.90							24.3	27.0
6.00							23.1	25.4
6.10							22.0	24.1
6.20							20.9	22.8
6.25							20.4	22.1

MULTIPROPS are classified according to official approval as follows:
 MP 250 = Class T 25 MP 480 = Class D 45
 MP 350 = Class R 35 MP 625 = Class D 60

Note:
 We recommend using the HD Wingnut Spanner, Item no. 022027, to release the loads > 60kN.
 MULTIPROP 350 and 480 clamped in the Table Swivel Head or UNIPORTAL Head fitted to PERI tableforms have permissible load of MP 350 minimum 56 kN, MP 480 minimum 36 kN over the entire extension range.



We are specialists in hiring out efficiency equipment which will save you precious time and money on your project.

We are proud to be Denmark's leading hire company of compact cranes. Our success is due to our dedication and expertise in the industry as well as the contractor business.

Top Class Service

We will assist you right from the beginning of your project. In cooperation with our engineering partner, we can provide you with counsel and calculations which will give you a perfect picture of the various options.

A World of Experience

We have great insight in how to handle and deliver the perfect result. This insight has been obtained through international cooperation with professional contractors worldwide.

Our Objective

Our objective is to deliver the best products and services to our customers while at the same time keeping it cost-effective. We continuously use the most effective and up-to-date technology, comply with the strictest security initiatives and focus on the environment.



Martin Bo Bojesen
Managing Director
Mobile: +45 31 640 550
Mail: mbb@prestonrentals.dk



Morten Bang
Head of SuperCrane™
Mobile: +45 21 440 555
Mail: morten.bang@prestonrentals.dk



Jan Jespersen
Business Developer
Mobile: +45 61 100 142
Mail: jan.jespersen@prestonrentals.dk

Contact and Services:

AARHUS:

Main Office

Preston Rentals Aps
Høgemosevej 29
DK - 8380 Trige

Phone: +45 31 640 550
Mail: mail@prestonrentals.dk

CVR-nr.: 39401835

SJÆLLAND:

Logistics

Preston Rentals Aps
Fabriksparken 11
DK - 2600 Glostrup

Phone: +45 31 640 550
Mail: mail@prestonrentals.dk

Find terms and conditions, brochures etc. on our website:

